

LIFT

LIFT MRT611

With a dual vacuum system, 1100 lbs [500 kg] load capacity, removable pad frame extensions and a remarkably low profile, this Powr-Grip® rotator/tilter provides maximum versatility and ease of use in tight work locations.

DIMENSIONS (mm)

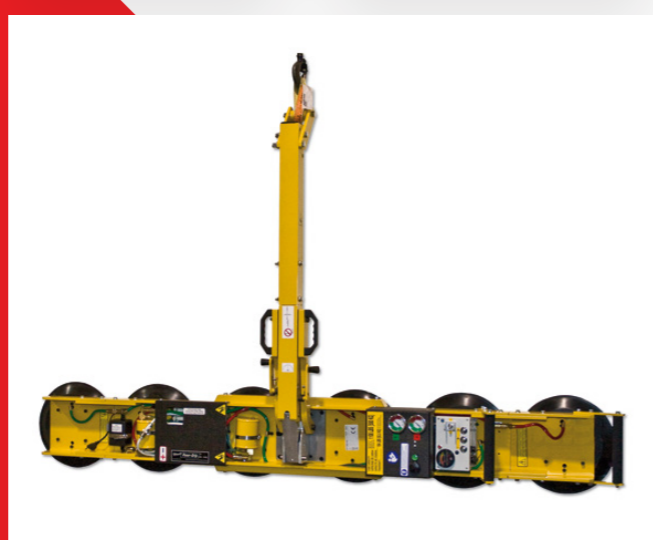
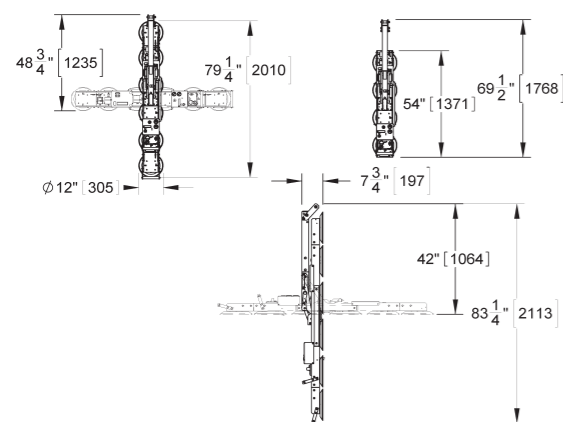

1100 LBS [500 KG] (WITH 6 PADS IN USE)
736 LBS [334 KG] (WITH 4 PADS IN USE)

- Ideally suitable for transport and installation in limited space conditions
- Compact, robust construction
- For construction sites and workshops
- High holding capacity and great safety due to dual circuit vacuum system
- Independent of power supply



SPECIFICATION

Maximum Load Capacity	1100 lbs [500 kg]
Load Movement	Manual rotation, 180° edgewise, with locking in 3 positions Assisted manual tilt, 90° between upright and flat, with automatic latching in upright position
Standard Features	Adjustable-position lift spool Dual vacuum system Low vacuum warning buzzer Green lift light On-board battery and charger Battery energy gauge Vacuum gauges Vacuum line filters Vacuum reserve tanks Spring-mounted vacuum pads Removable pad frame extensions Blow-off for quick release
Dual Vacuum System	Features two completely independent vacuum circuits. Provides vacuum system redundancy. Limits possibility of a catastrophic failure. Reduces chance of harm to personnel or equipment.
Available Options	Alternative vacuum pads (Specifications not as listed above. Please contact us for more information): 9" [23 cm] diameter pad (VPFS9) 10" [25 cm] diameter, concave pad (G0750) 10" [25 cm] diameter, lipped pad (HV11) Remote control system (57388) Movable control pendant (59040) and 120" [305 cm] Extension cable (59040AM) Alternative pad compounds, including ones for low-marking, temperature resistant and coated surface applications (special order) Counterbalance Lifter (CB2DCS)
Profile Thickness	7 3/4" [197 mm] (does not include load)
Standard Operating Power	12 volts DC, 10 amps
Standard Pad Spread	With 6 pads in use: 79 1/4" x 12" [2010 x 305 mm] With 4 pads in use: 54" x 12" [1371 x 305 mm]
Number / Size of Pads	6 / 11" [28 cm] diameter, lipped
Unit Weight	130 lbs [59 kg]
Design Standards	ASME B30.20 (BTH-1 Design Category "B", Service Class "0") CE (See www.WPG.com for more information.)

